



# INSULATION COMPONENTS

## National Electrostatics Corp.

## Acceleration Tubes

### APPLICATIONS

The NEC all-metal and ceramic assemblies are ideal for applications which require ultra high vacuum capability in regions of high voltage or where a complete insulating barrier is required.

NEC offers two different styles of acceleration tubes based on application: the general purpose acceleration tube designed for use in ambient air conditions, and the high gradient acceleration tube designed for use in 80 psig SF<sub>6</sub> insulating gas.

These tubes have been in use on a routine basis in very strenuous conditions for periods of over 40 years with no signs of degradation. The NEC acceleration tubes do not show the usual aging characteristics of the older style glass and epoxy acceleration tubes even after tens of thousands of hours of use.

### DESIGN

NEC employs two types of metal/ceramic bonding processes. The first is a standard metal to ceramic braze, which is used in the NEC general purpose acceleration tube. These assemblies are fully bakeable to 500° C.

For assemblies that require higher voltage gradients, NEC has developed a unique metal diffusion bond that has proven to be very reliable in high voltage gradient environments. This bonding technique is utilized in the high gradient and non-magnetic acceleration tubes. These assemblies can be baked to 200° C.

All NEC tubes are insensitive to thermal shock and exhibit exceptional mechanical strength.

All of the metal/ceramic assemblies are equipped with either aluminum or titanium electrodes. Terminations are standard NEC flanges, ConFlat flanges, or custom flanges made to your specifications.



*One million Volt assembly of high gradient acceleration tube sections designed for operation in 80 psig SF<sub>6</sub> insulating gas.*



*300kV assembly of four general purpose acceleration tube sections designed to operate in dry, clean air.*

# General Purpose Acceleration Tube

## APPLICATIONS

The NEC general purpose acceleration tube section is designed for operation in clean, dry, ambient air. A non-magnetic model of the general purpose acceleration tube is also available and is designed for the acceleration of low energy electron beams that are adversely affected by proximity of ferromagnetic materials.

These metal and ceramic brazed general purpose acceleration tube sections are in use on all NEC open air ion beam systems up to 500kV.

## DESIGN

The all metal and ceramic general purpose acceleration tube section is a metal brazed assembly with no organic compounds in the vacuum volume. This tube is fully bakeable for contaminant free and ultra high vacuum operation. There are no ferromagnetic materials in the non-magnetic model.

Each section is conservatively rated at 75kV. Multiple sections can be combined to achieve needed voltage. The optimum voltage holding capability is dependent on ambient conditions. The recommended dew point is less than 10° C in a dust free environment. Individual sections are assembled and sealed via aluminum wire or gold wire gaskets.

Should an accident occur that damages the interior of the acceleration tube, the internal electrodes can be removed for abrasive blasting of individual tube sections.

The exterior field is defined by demountable potential distribution rings. Potential grading is provided by ten 150MOhm resistors in series.

The tube must be supported against its end ceramic ring at both ends of the tube. The tube section cannot be cantilevered from one end only.

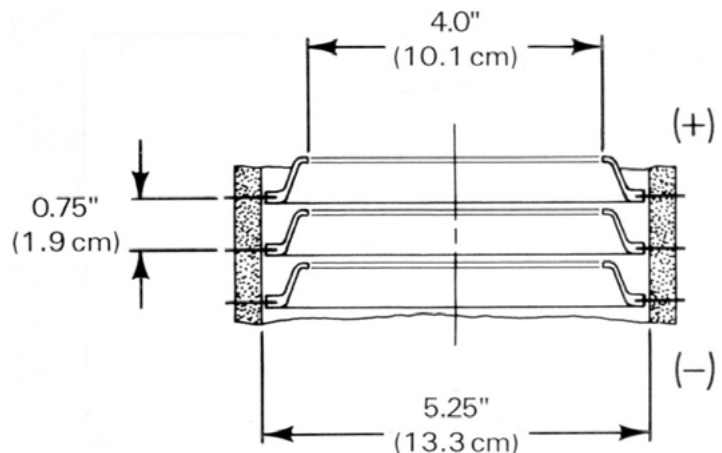

*Cross-sectional view showing detachable internal electrodes of the general purpose acceleration tube section. Dimensions vary slightly for non-magnetic model*

# SPECIFICATIONS

<b>Voltage Rating:</b>	75kV in air (1atm.) 200kV in SF <sub>6</sub> (2 atm.) (for internal pressure less than 5 x 10 <sup>-5</sup> Torr)
<b>Beam Currents:</b>	Designed for accelerating intense beams of heavy and light ions
<b>Ultimate pressure:</b>	Less than 1 x 10 <sup>-9</sup> Torr, after bakeout
<b>Bakeable:</b>	To 500° C maximum (200° C maximum for non-magnetic model)
<b>Modulus:</b>	0.770" (1.96cm)
<b>Ceramic:</b>	Standard: Alumina, 6" O.D., 5.25" I.D. Non-magnetic: Alumina, 5.625" I.D.
<b>Length:</b>	Standard: 9.660" (24.5cm) gasket surface to gasket surface Non-magnetic: 9.25" (23.5cm) gasket surface to gasket surface
<b>Electrode insert aperture:</b>	4" (10.2cm) I.D.
<b>Resistors:</b>	10 x 150MΩ resistors in series
<b>Flanges:</b>	8.0" O.D. NEC or ConFlat flanges (other flange sizes and types may be available upon request)

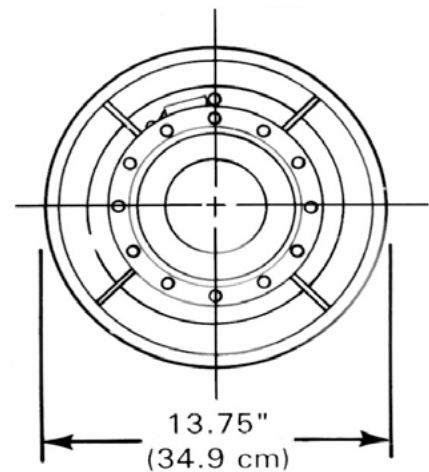
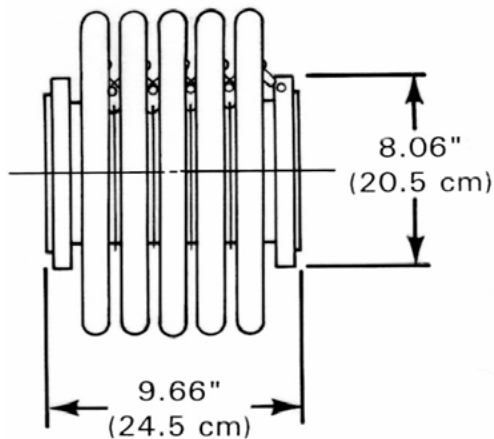

# High Gradient Acceleration Tube

## APPLICATIONS

The NEC high gradient acceleration tube section is designed for operation in high pressure SF<sub>6</sub> gas.

These all metal and ceramic high gradient acceleration tube sections were originally designed for use in the NEC Pelletron® accelerator systems. They have proven to be very reliable in Pelletron accelerators ranging from below 1MV to above 25MV terminal potentials.

There are two sizes of the high gradient acceleration tube: the standard (4.0" I.D.) model and the large (5.63" I.D.) model. The large high gradient acceleration tube was originally designed to replace original tubes in the radiocarbon Dynamics, Inc. Dynamitrons.

## DESIGN

The all metal and ceramic high gradient acceleration tube section is a metal bonded assembly with no organic compounds in the vacuum volume. This tube is fully bakeable for contaminant free and ultra high vacuum operation. Tube sections are available in several standard lengths. Each gap of the standard tube is rated at a conservative 30kV (16kV for the large model) when used in Pelletron accelerators.

Should an accident occur that damages the interior of the acceleration tube, the flat field internal electrodes can be removed for abrasive blasting of individual tube sections. The exterior ceramic surfaces are protected via toroidal spark gaps. During operation, radiation is kept to a minimum via aperture limitation of electron trajectories combined with magnetic suppression.

For use in Pelletron accelerators, potential grading is usually provided with a point to plane corona distribution system or resistor divider. Further information is available upon request.

The large high gradient acceleration tube is of similar construction to the well proven standard high gradient tube with the overall dimensions increased to handle larger diameter ion beams.

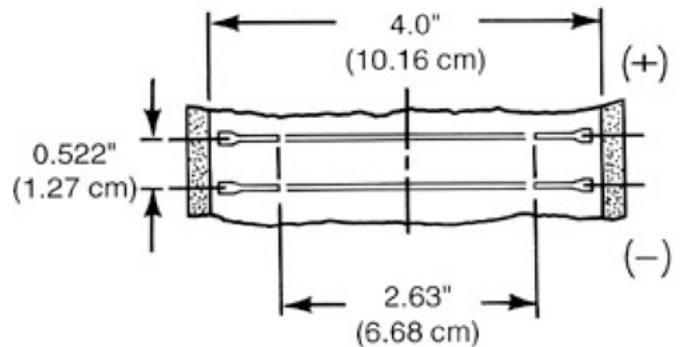

*Cross-sectional view showing detachable internal electrodes of the high gradient acceleration tube section*

# SPECIFICATIONS

Voltage Rating:	500kV in SF <sub>6</sub> gas at 80 psig for 22-gap section (internal pressure is less than 5 x 10 <sup>-5</sup> Torr)
Beam Currents:	Designed for accelerating intense beams of heavy ions and electrons
Ultimate pressure:	Less than 1 x 10 <sup>-9</sup> Torr, after bakeout
Bakeable:	To 200° C maximum
Modulus:	Standard: 0.522" (1.32cm) Large: 0.5" (1.27cm)
Ceramic:	Standard: Alumina, 4.375" O.D., 4" I.D. Large: Alumina, 6" O.D., 5.625" I.D.
Electrode insert aperture:	Standard: 2.625" (6.67cm) I.D. There is a decoupling aperture of 1" I.D. between each tube section Large: 3.25" (8.26) I.D.
Resistors:	10 x 150MΩ resistors in series
Flanges:	Standard: 6.44" (16.3cm) O.D. NEC flange Large: 9.0" (22.86cm) O.D. NEC flange (other flange sizes and types may be available upon request)

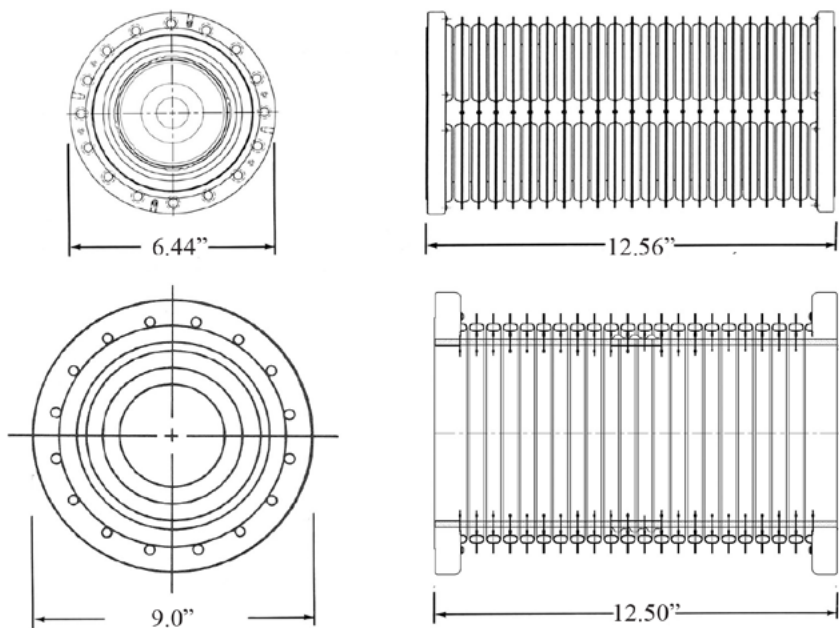

## Contact NEC

[www.pelletron.com](http://www.pelletron.com)

+1 (608) 831-7600

[nec@pelletron.com](mailto:nec@pelletron.com)

7540 Graber Rd, Middleton, WI 53562-0310 USA