



# VACUUM COMPONENTS

## National Electrostatics Corp.

## Gas Metering Vacuum Valve

### DESIGN

Reliable all-metal valves manufactured by NEC utilize the principle of a stainless steel knife edge embedded into a softer metal seal of either aluminum or gold. Although the actual mechanism may vary in appearance, the NEC valves universally employ a toggle mechanism which provides constant seal forces until an external adjustment is necessary.

Whether actuated by hand, air, or other remote method, the unique NEC toggle mechanism provides a sealing force independent of operator or facility variations. Longer seal life is the natural result.

### METERING VALVES

These valves readily adjust to a helium mass spectrometer leak tight condition for fine control of gases into ultra-high vacuum from bottle pressures in excess of 2000 psi. The fact that all materials in the vacuum volume are UHV compatible contributes to the uniqueness of these valves. Moreover, the external construction provides ambient pressure isolation and can operate in environments ranging from rough pump vacuum to over 200 psi.

Variations of this valve include manual and motorized versions. Motors currently offered include 60 Hz, 400 Hz and stepper options. Motor drive packages can also be provided which allow voltage isolation of 5 kV between valve and motor.



*All-metal gas metering valve with 1/4" O.D. tube ends.*

## APPLICATIONS

The NEC all-metal gas metering valve is ideally suited for applications requiring the fine control of gas flow into a vacuum where corrosive gases are used or ultra-clean conditions are a requirement. There are no organic compounds inside the operating vacuum volume of this valve.

The NEC metering valve regulates the flow of gas from vacuum tight shut-off to rates exceeding 100 atm-cc/hr. Input pressures can be as high as 2000 psi.

The original applications for these valves include the control of gas flow into ion beam sources and the control of gas flow into ion beam stripper canals in the terminals of NEC Pelletron® accelerators.

## DESIGN

The valve mechanism consists of a slightly curved flexure strip which axially loads a soft gold seat into a stainless steel knife edge. As a transverse load is applied to the strip, it tends to straighten, thereby applying a sealing force.

The sensitivity is controlled by the extent the flexure has been straightened upon contact with the knife edge. This extent is adjustable by means of a manual adjustment screw. The flow rate is controlled by a differential screw which provides the transverse load to the flexure strip.

The valve head assembly can be reoriented to position the outlet port to meet your specific requirements. The standard valve seat is 24K gold. Aluminum or nickel are also available as seat material.

All materials in the vacuum volume are UHV compatible. No o-rings or other seals containing organic compounds are used.

This stainless steel valve is fully ambient pressure isolated which is ideal for operation in environments that vary from high vacuum to high pressure.

The basic valve is provided with a manual graduated knob. Remote versions are available with either 60 Hz, 400 Hz or stepper motor drives. A multi-turn positive read-out potentiometer and limit switches are included in the drive.

The standard inlet and outlet tubes are 0.25" O.D. stainless steel tubing. Custom welded fittings or flanges are available upon request.

## SPECIFICATIONS

---

■ <b>Connection:</b>	Standard inlet and outlet tubes are 0.25" O.D., stainless steel. Custom fittings and flanges are available.
■ <b>Maximum Inlet Pressure:</b>	2000 psi
■ <b>Flow Rates:</b>	Less than $2 \times 10^{-10}$ atm-cc/sec to 100 atm-cc/hr.
■ <b>Seat Material:</b>	Gold (standard)

---

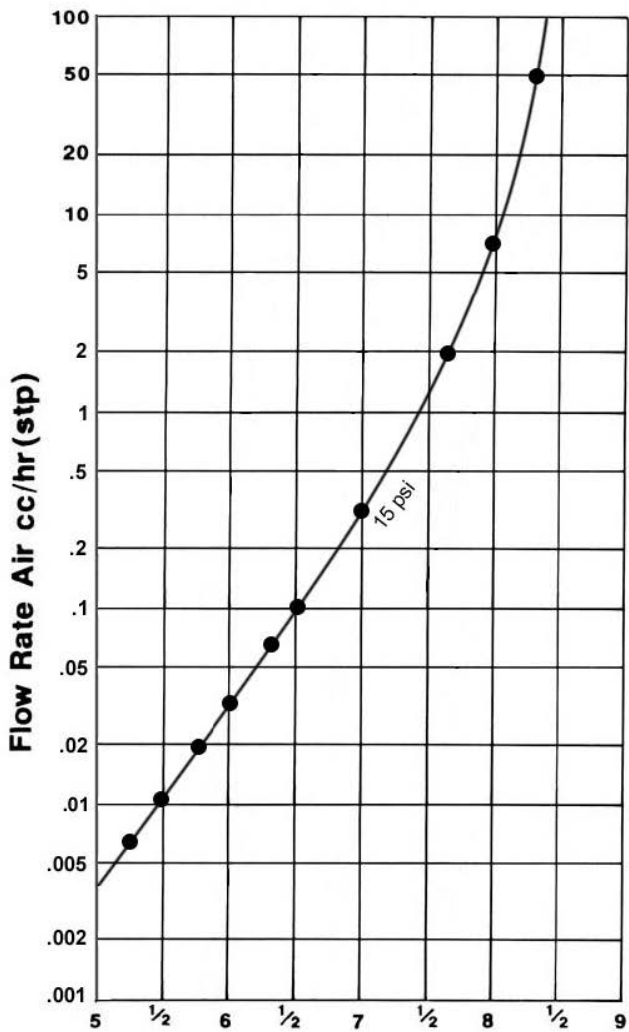

**Number of Turns**  
 Typical flow rate vs. shaft rotation  
 for 15 psia inlet pressure

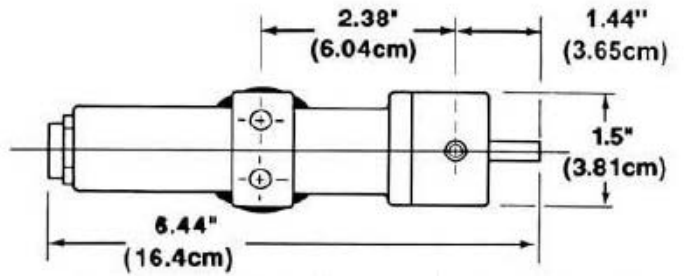

Outlet tube angle supplied as shown. Customer can reorient to any other of the 90° positions, but valve control sensitivity will change from the factory setting.

Valve head assembly is replaceable.

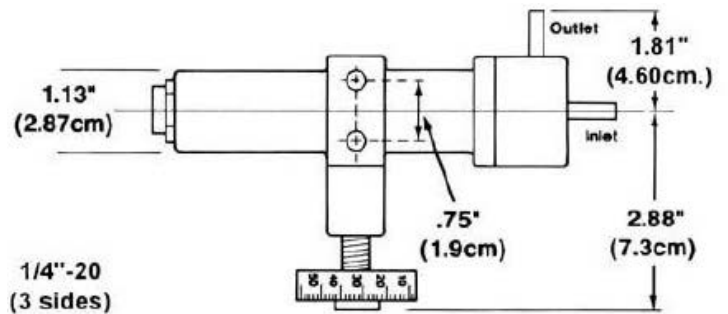

## Contact NEC

[www.pelletron.com](http://www.pelletron.com)

+1 (608) 831-7600

[nec@pelletron.com](mailto:nec@pelletron.com)

7540 Graber Rd, Middleton, WI 53562-0310 USA