

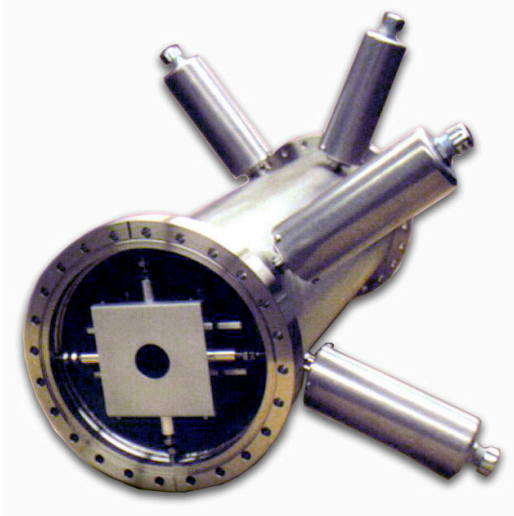

BEAM HANDLING COMPONENTS

National Electrostatics Corp.

Electrostatic Ion Beam Raster Scan System



The NEC Ion Beam Raster Scanner with 10" O.D. ConFlat flanges.

The beam clearance between the scanning plates is 3.8cm and the plate length is 30.5cm. The electrical vacuum feedthroughs in the vacuum housing allow a maximum of 15kV to be applied to each plate. Using $\pm 10\text{kV}$, for a potential of 20kV plate to plate, the maximum scanned angle for a 3MeV doubly charged ion is $\pm 3.0^\circ$. Therefore, after a drift of 2 meters, the ion beam is moved 105mm from center.

ACCESSORIES

The raster scanner assembly, when used with the related power supply and controller, provides a very reliable system for uniform ion beam deposition into flat targets.

APPLICATIONS

The NEC Raster Scan System was originally designed for NEC ion implanters. In this case, the raster scanner sweeps 3MeV doubly charged ions across wafers with a maximum diameter of 150mm. It is also incorporated in ion beam analysis beamlines on Pelletron® systems. This unique ion beam system is ideal for all applications that require uniform ion beam deposition across a large flat target.

DESIGN

The raster scanner assembly consists of four electrostatic plates, two vertical and two horizontal. The entire assembly is contained in a 20cm diameter housing. As with most NEC components, there are no organic compounds in the vacuum volume. The entire assembly is fully bakeable and ultra-high vacuum compatible.

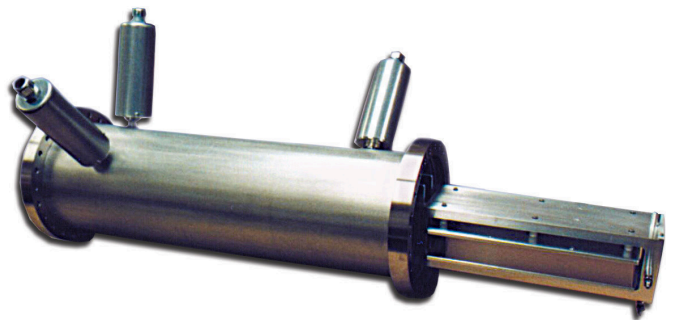

Inner assembly exposed. All plates are attached to an inner support structure to assure proper alignment.

POWER SUPPLY

The raster scanner power supply is designed to be positioned near the raster scanner assembly.

This power supply provides $\pm 10\text{kV}$ at 517Hz for the horizontal scanning plates and 64Hz for the vertical scanning plates. The ratio of the horizontal to vertical scanned frequencies is crystal locked to optimize scan uniformity. Transformer coupling assures the complete absence of DC offset voltages.

CONTROLLER

The raster scanner controller is equipped with two 10-turn potentiometers for separate control of the horizontal and vertical scanning plate voltages. Each set of plates can be turned off individually to allow set up of one scan direction at a time. The controller allows input from customer supplied contact closure for status interlocks. In addition, the controller has an internal contact pair whose

DESIGN CAPABILITIES

The Raster Scan System was originally designed to scan 2MeV singly charged ions across a 6" silicon wafer.

Below is the equation to determine capabilities for ions with other energies and charge states.

The following equation below gives the tangent of the half angle (α) which is used to determine the maximum scan diameter at the target.

closure indicates high voltage enable. This is ideal for use with an ion implanter process controller.

The high voltage output is monitored by compensated attenuators to provide a 1V monitor signal per 5kV output voltage. These signals are available separately for each of the four deflection plates. Also, a signal is provided for plate-to-plate voltage monitoring. The signals are made available for oscilloscope display.

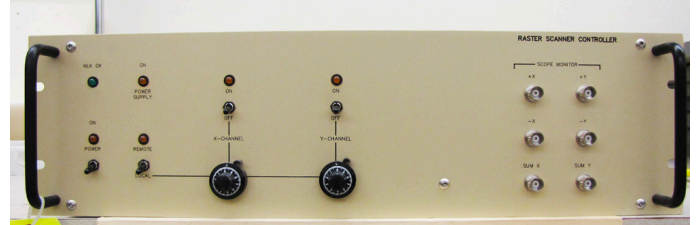

Controller for the NEC electrostatic raster scanner.

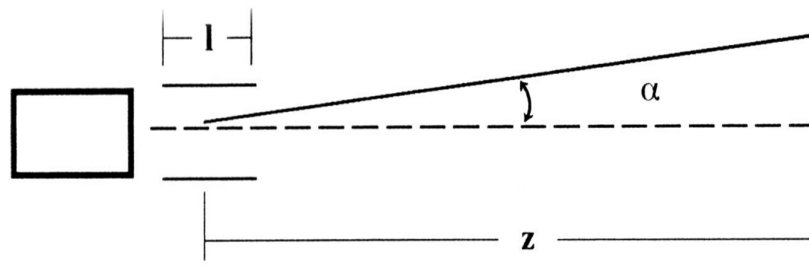

$$\tan \alpha = \frac{qVl}{2dE}$$

- q = ion charge state
- V = voltage between plates (kV) ($V < 20\text{kV}$)
- l = plate length = 12"
- d = spacing between plates = 1.5"
- E = ion beam energy (keV)
- z = distance from middle of second plate to target

Please note: It is recommended that the half angle (α) not be greater than 3.0° .

SPECIFICATIONS

Raster Scanner	
Overall Length:	27.625" (70.17cm) gasket surface to gasket surface
Flanges:	10" O.D. ConFlat or NEC flanges standard
Length of Deflection Plates:	12.0" (30.48cm)
Separation of X Pair from Y Pair:	0.5" (1.27cm)
Plate Separation:	1.5" (3.81cm)
Entrance Aperture:	1.25" (3.2cm) diameter, aluminum (tantalum optional).
Maximum Scanned Angle:	± 3.0°, for 3MeV doubly charged ions ± 2.2°, for 2MeV singly charged ions
Voltage Supply and Control:	See power supply specifications
Vacuum Feedthrough Rating:	15kV (30kV plate to plate)

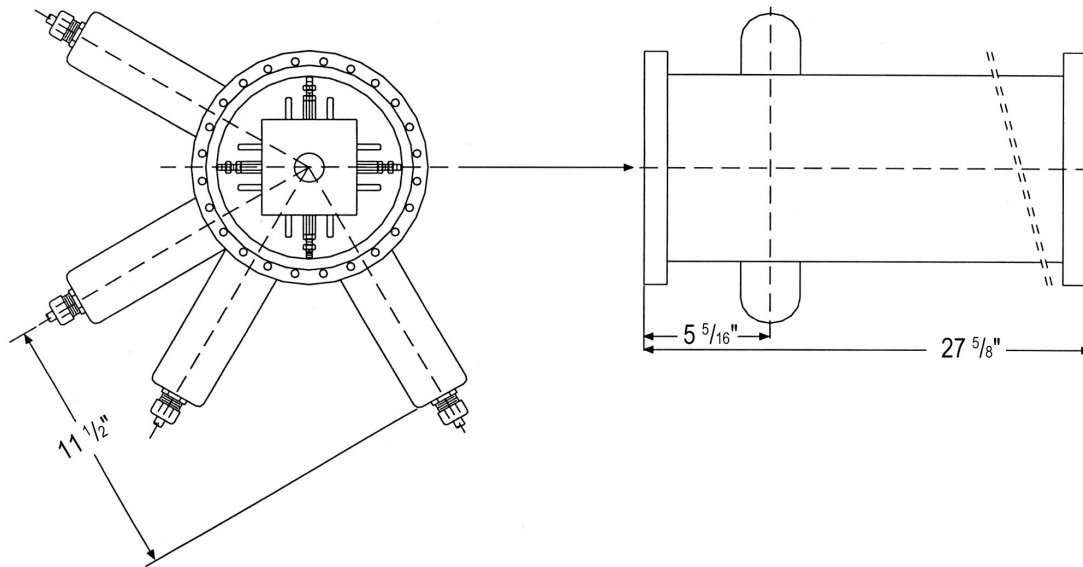

ORDERING INFORMATION

Catalog No.: 2EA058010 (CF flanges)

2EA058030 (NEC Flanges)

SPECIFICATIONS

Raster Scanner Power Supply and Controller

Power supply performance is guaranteed only when used with the NEC electrostatic raster scanner.

Output Voltage:	0kV to 20kV (plate to plate)
Output Current:	4mA maximum
Output Frequencies:	517Hz horizontal, 64Hz vertical (crystal locked)
Allowable Load Capacitance:	50 pF to ground using output cables provided
Sweep Linearity:	dv/dt is within 5% over duration of scan within 5% of each voltage peak
Output Monitoring:	Monitor signals, 1V/5kV, provided for each plate Signals are made for oscilloscope display Plate-to-plate monitor signal is also present
Control:	10-turn potentiometer and ON/OFF switch control for each scan direction
Interlocks:	High voltage is switched off by customer supplied contact closure, high voltage "on" is indicated by internal contact enclosure
Input Power:	120/240 VAC, 4/2A max., 50-60Hz controller requires only 0.5/0.25A

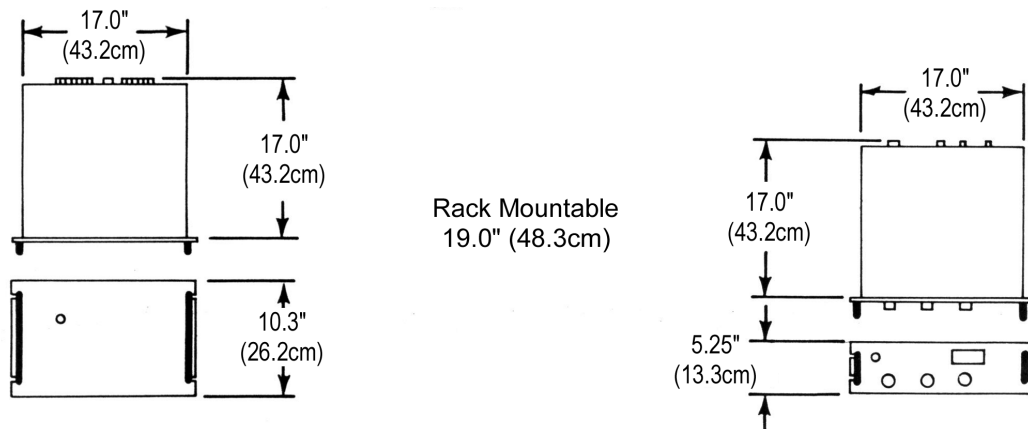

ORDERING INFORMATION

High Voltage Unit
Cat No.: 2HA070490

Controller
Cat No.: 2HA064460

Contact NEC

 www.pelletron.com

 +1 (608) 831-7600

 nec@pelletron.com

 7540 Graber Rd, Middleton, WI 53562-0310 USA